

DDL-8500-7 Series

PARTS LIST

29299906
No.1202-00

1. MACHINE FRAME & MISCELLANEOUS COVER

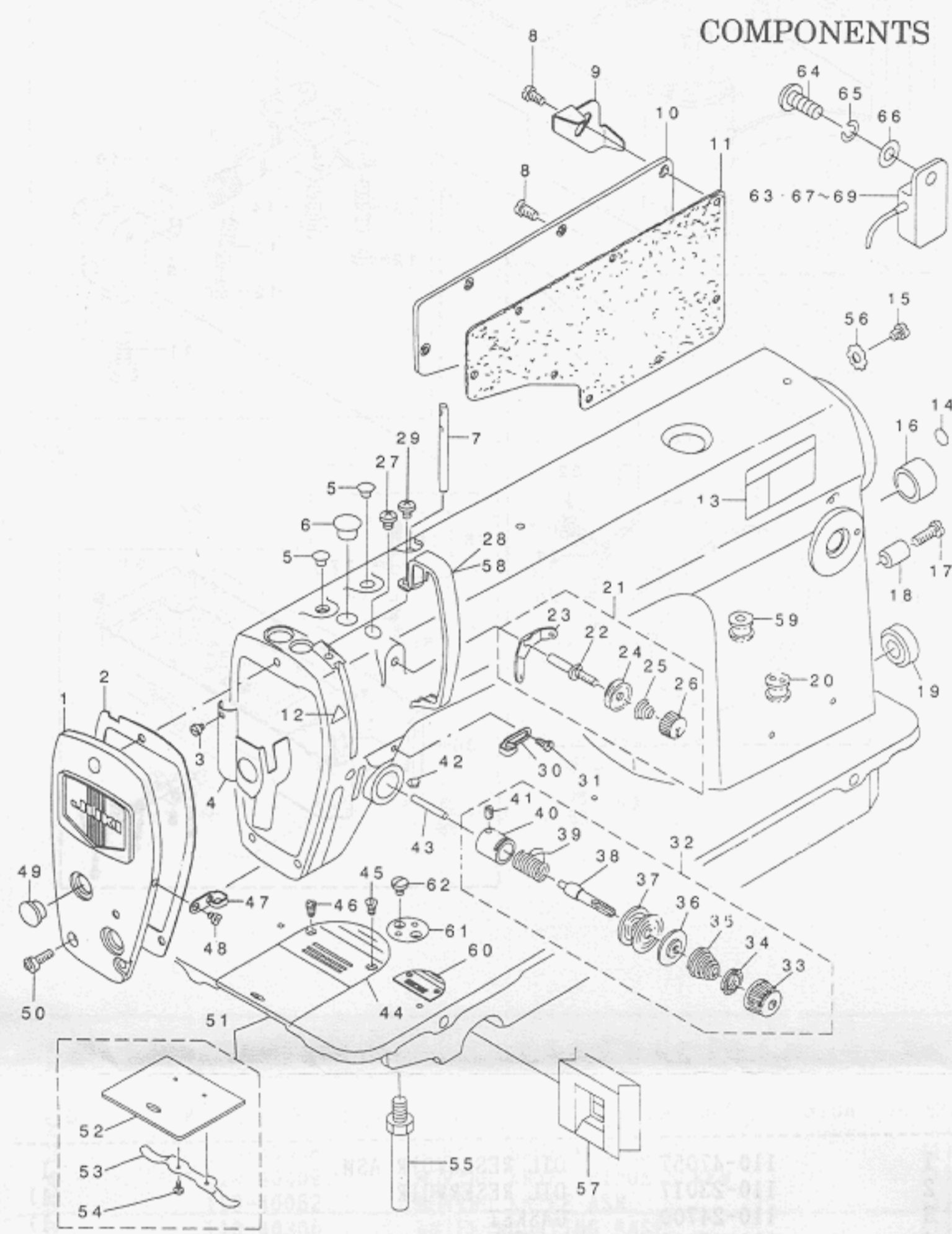

REF.NO	NOTE	PART NO.	DESCRIPTION	Qty
1		229-02159	FASE PLATE ASM.	1
2		229-02209	FASE PLATE GASKET	1
3		SS-6080410-SP	SCREW 1/8-44 L=4	1
4		229-00757	ARM OIL SHIFLD ASM.	1
5		TA-0850604-R0	RUBBER PLUG	2
6		TA-1250705-R0	RUBBER PLUG	1
7		229-58300	THREAD GUIDE ROD	1
8		SS-4120915-SP	SCREW 3/16-28 L=9	8
9	#05	229-54705	CORD HOLDER	1
10		229-00401	SIDE PLATE	1
11		110-00619	GASKET	1
12	#01	CH-3002000-01	ATTENTION SEAL	1
13	#06	CH-3002001-A1	SAFETY LABEL.,3 (SMALL).	1
14		100-04109	GROUND MARK	1
15		SS-4120615-SP	SCREW 3/16-28 L=6	1
16		TA-2000502-R0	RUBBER PLUG	1
17	#02	SS-6121840-SP	SCREW 3/16-28 L=18	1
18	#02	229-52501	REVERSE FEED LEVER STOPPER	1
19		TA-2101002-R0	RUBBER PLUG	1
20	#02	229-35308	MAGNET CORD RUBBER	1
21		229-45455	THREAD TENSION ASM.	1
22		229-45406	FIRST TENSION POST	(1)
23		229-45604	THREAD TENSION GUIDE	(1)
24		229-45802	BOBBIN WINDER TENSION DISC	(2)
25		229-45505	THREAD TENSION SPRING	(1)
26		229-45703	THREAD TENSION NUT	(1)
27		SS-4120615-SP	SCREW 3/16-28 L=6	1
28		229-00609	THREAD TAKE-UP LEVER COVER	1
29		SS-4120615-SP	SCREW 3/16-28 L=6	1
30		229-20508	ARM THREAD GUIDE A	1
31		110-01500	SCREW	1
32		229-45356	THREAD TENSION ASM.	1
33		229-21308	TENSION NUT	(1)
34		229-21407	ROTATING STOPPER	(1)
35		229-21704	TENSION SPRING A	(1)
36		229-21803	THREAD TENSION DISK PRESSER	(1)
37		229-21506	THREAD TENSION DISK	(2)
38		229-21209	TENSION POST	(1)
39		229-21605	TAKE-UP SPRING	(1)
40		229-45307	TENSION POST SOCKET	(1)
41		SS-8090670-SP	SCREW 9/64-40 L= 5.5	(1)
42		SS-8150710-SP	SCREW 15/64-28 L=7	1
43		B3118-552-E00	TENSION RELEASING	1
44		B1109-012-10B	THROAT PLATE (I)	1
45		SS-2110920-TP	SCREW 11/64-40 L=8.5	1
46		SS-2110915-SP	SCREW 11/64-40 L=8.5	1
47		229-20607	ARM THREAD GUIDE B	1
48		SS-6110610-TP	SCREW 11/64-40 L=6	1
49		TA-1250406-R0	RUBBER PLUG D=12.5 L=4	2
50		SS-4120915-SP	SCREW 3/16-28 L=9	3
51		229-01250	BED SLIDE ASM.	1
52		229-01201	SLIDE PLATE	(1)
53		229-01300	BED SLIDE SPRING	(1)
54		SS-6060210-SP	SCREW 3/32-56 L= 1.9	(2)
55		229-01003	BED SCREW STUD	4
56		WT-0530002-KS	TOOTHED WASHER D=5.3	1
57		229-35407	RUBBER PLATE	1
58	#01	180-77503	THREAD TAKE-UP LEVER COVER	1
59	#03	229-35209	RUBBER BUSHING	1
60	#04	B1109-552-000	THROAT PLATE	1
61		229-02605	RULER STOPPER	1
62		SS-7110540-SP	SCREW 11/64-40 L=5	2
63		M6008-350-AAC	RESISTANCE PACK AC ASM.	1
64		SS-4121215-SP	SCREW 3/16-28 L=12	1
65		WS-0510002-KP	SPRING WASHER 5.1X9.2X1.3	1
66		WP-0501016-SD	WASHER 5X10.5X1	1
67	#04	M6008-350-AAA	RESISTANCE PACK AA ASM.	1
68	#01	M6008-350-AAF	RESISTANCE PACK AF ASM.	1
69	#07	M6008-350-AAL	RESISTANCE PACK AL ASM.	1

Note #01...FOR JE
#02...FOR DDL-8500-7-0B,-WB
#03...FOR DDL-8500-7-00
#04...FOR JA
#05...EXCEPT DDL-8500-7-00
#06...EXCEPT JE
#07...FOR JH

3. NEEDLE BAR, UPRIGHT SHAFT & HOOK DRIVING SHAFT COMPONENTS

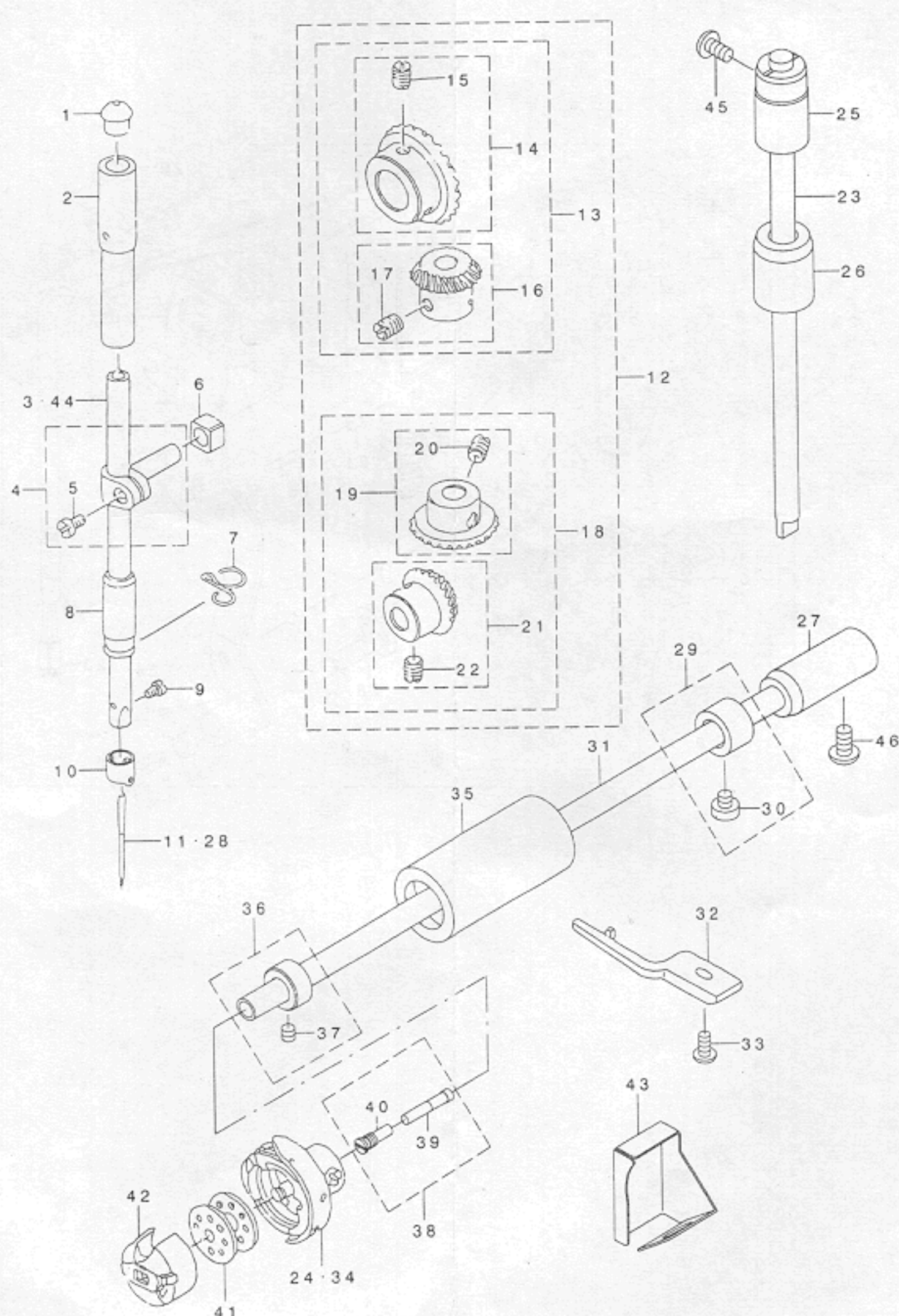

REF. NO	NOTE	PART NO.	DESCRIPTION	Qty
1		229-01409	CAP	1
2		229-06101	NEEDLE BAR BUSHING ,UPPER	1
3		229-39508	NEEDLE BAR	1
4		229-06457	NEEDLE ROD HOLDER ASM.	1
5		SS-6090670-TP	SCREW 9/64-40 L=6	(1)
6		229-06507	SLIDE BLOCK	1
7		110-18801	NEEDLE BAR THREAD GUIDE	1
8		229-06200	NEEDLE BAR BUSHING, LOWER	1
9		SS-7080510-TP	SCREW 1/8-44 L=4.5	1
10		229-06309	NEEDLE BAR THREAD GUIDE	1
11		MDB-100B1400	NEEDLE DBX1 #14	1
12		B1306-155-0C0	GEAR & PINION ASM.	1
13		B1306-155-0B0	GEAR & PINION ASM., UPPER	(1)
14		B1305-012-0A0	GEAR ASM.	(1)
15		SS-8660810-TP	SCREW 1/4-40 L=8	(2)
16		B1306-155-0A0	PINION ASM.	(1)
17		SS-8660810-TP	SCREW 1/4-40 L=8	(2)
18		B1307-155-0B0	GEAR & PINION ASM., LOWER	(1)
19		B1307-155-0A0	GEAR ASM. LARGE	(1)
20		SS-8660810-TP	SCREW 1/4-40 L=8	(2)
21		B1308-155-0A0	PINION ASM.	(1)
22		SS-8660810-TP	SCREW 1/4-40 L=8	(2)
23		229-05004	UPRIGHT SHAFT	1
24		111-41355	HOOK ASM.	1
25		229-05103	UPRIGHT SHAFT BUSHING ,LOWER	1
26		229-05202	UPRIGHT SHAFT BUSHING ,LOWER	1
27		229-16308	BUSHING ,REAR	1
28	#02	MC-2005009-00	NEEDLE 134 90	1
29		229-17157	THRUST COLLAR ASM.	1
30		SS-6110420-TP	SCREW 11/64-40 L=4.8	(2)
31		229-16001	LOWER SHAFT	1
32		229-42502	BOBBIN CASE HOLDER	1
33		SS-4110915-SP	SCREW 11/64-40 L=9	1
34	#01	110-38650	HOOK ASM.	1
35		229-16100	LOWER SHAFT FRONT METAL	1
36		229-17058	THRUST COLLAR ASM.	1
37		SS-8110410-TP	SCREW 11/64-40 L= 3.5	(2)
38		229-16555	OIL SEAL SCREW ASM.	1
39		229-16605	OIL WICK	(1)
40		229-16506	OIL SEAL SCREW	(1)
41		229-32909	BOBBIN	1
42		110-38759	BOBBIN CASE ASM.	1
43		229-42601	OIL SHIELD	1
44	#03	111-41207	NEEDLE BAR	1
45		SS-4120915-SP	SCREW 3/16-28 L=9	1
46		SS-4120915-SP	SCREW 3/16-28 L=9	1

Note #01....FOR JH
 #02....FOR JE
 #03....FOR JE,j0

4. HAND LIFTER COMPONENTS

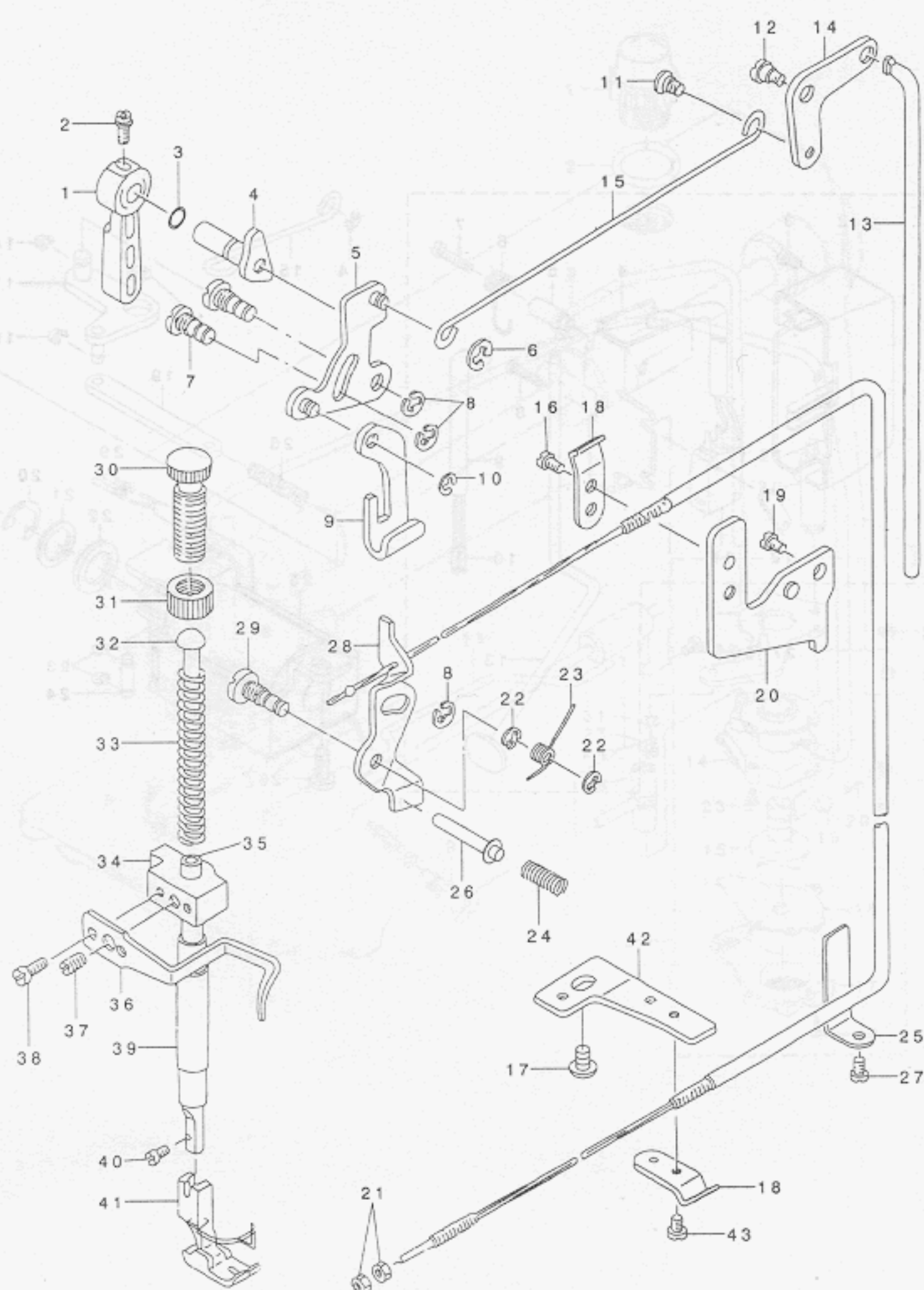

REF.NO	NOTE	PART NO.	DESCRIPTION	Qty
1		229-07802	HAND LIFTER	1
2		B1521-555-000	SCREW	1
3		RO-0371801-00	RUBBER RING	1
4		229-08552	HAND LIFTER CAM ASM.	1
5		229-08156	HAND LIFTER LINK	1
6		RE-0500000-K0	E-RING	1
7		110-06509	LINK SHAFT	2
8		RE-0500000-K0	E-RING	3
9		229-08008	LIFTING LEVER	1
10		RE-0500000-K0	E-RING	1
11		229-08909	HINGE SCREW	1
12		SD-0720331-SP	HINGE SCREW D= 7.24 H= 3.3	1
13		229-09006	CONNECTING ROD VERTICAL	1
14		229-08800	LIFTING LEVER LINK	1
15		229-08305	LIFTING LEVER CONNECTING ROD	1
16		SS-7110720-SP	SCREW 11/64-40 L=7	1
17	#01	SS-4150915-SP	SCREW 15/64-28 L=9	1
18		229-44508	WIRE HOLDER A	2
19		SS-4120615-SP	SCREW 3/16-28 L=6	1
20		229-44607	WIRE HOLDER BRACKET ,UPPER	1
21		NS-6620310-SP	NUT 3/16-32	2
22		RE-0500000-K0	E-RING	2
23		229-20201	TENSION RELEASE RETURN SPRING	1
24		110-18405	TENSION RELEASE PIN SPRING	1
25		229-45109	WIRE CABLE HOLDER	1
26		110-18306	TENSION RELEASE SUPPORTING PIN	1
27		SS-4120615-SP	SCREW 3/16-28 L=6	1
28		229-44854	THREAD RELEASE WIRE ASM.	1
29		110-18108	TENSION RELEASE SHAFT	1
30		229-07505	PRESSER ADJUSTING SCREW	1
31		229-07604	PRESSER ADJUSTING SCREW NUT	1
32		229-07703	PRESSER GUIDE BAR	1
33		229-07406	PRESSER ADJUSTING SPRING	1
34		229-07208	PRESSER BAR GUIDE BRACKET	1
35		229-07000	PRESSER BAR	1
36		229-07307	PRESSER BAR THREAD GUIDE	1
37		SS-8660810-TP	SCREW 1/4-40 L=8	1
38		SS-6090910-SP	SCREW 9/64-40 L=9	2
39		229-07109	PRESSER BAR BUSHING, LOWER	1
40		SS-7091110-SP	SCREW 9/64-40 L=10.5	1
41		B1524-012-OBA	PRESSER FOOT ASM.	1
42		229-44706	WIRE HOLDER BRACKET ,LOWER	1
43		SS-7110410-SP	SCREW 11/64-40 L=4	1

Note #01....FOR DDL-8500-7-00

5. FEED MECHANISM COMPONENTS

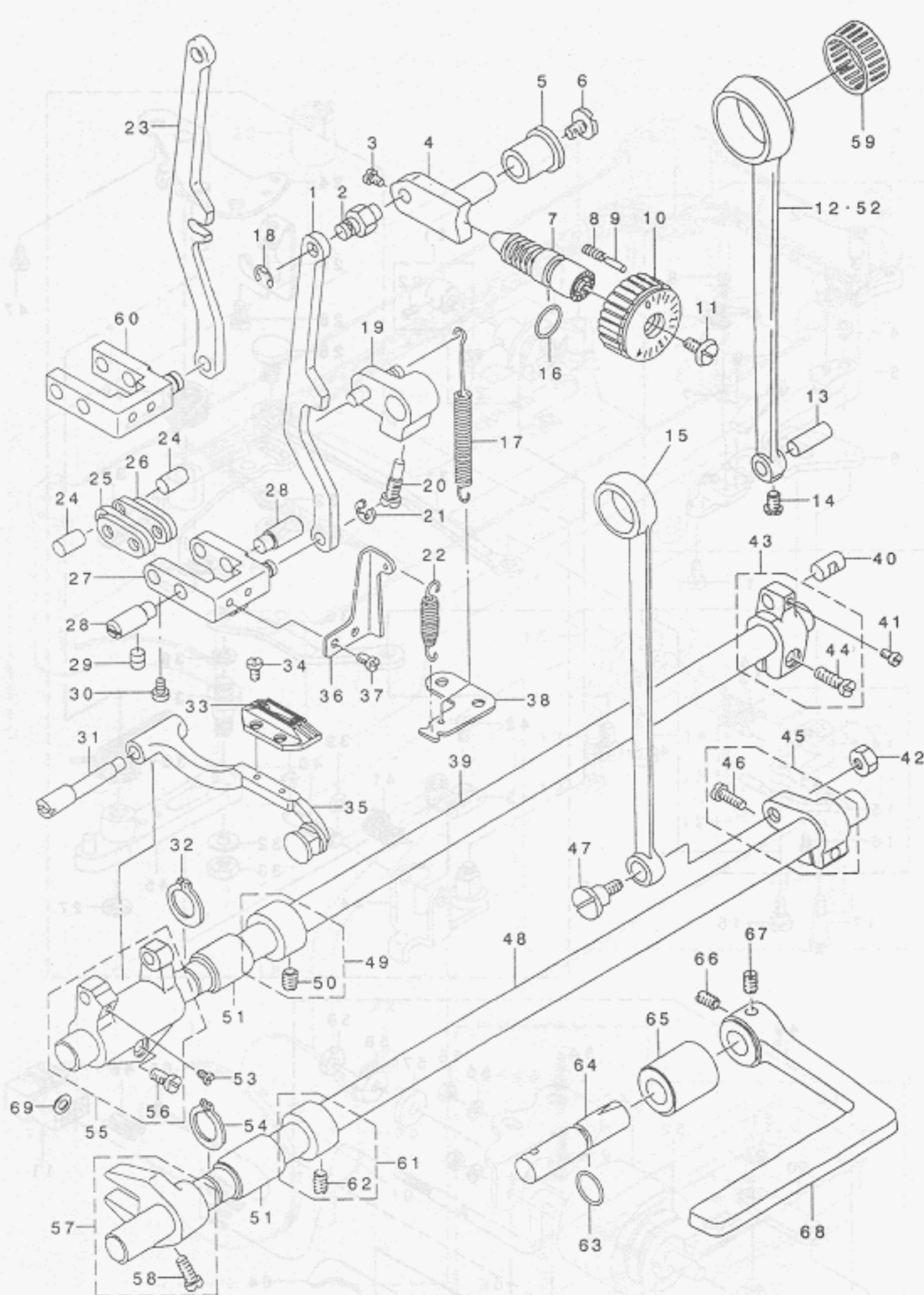

REF. NO	NOTE	PART NO.	DESCRIPTION	Qty
1	#01	229-41108	FEED ADJUST ROD	1
2		229-11507	FEED REGULATOR PIN	1
3		SS-6090670-TP	SCREW 9/64-40 L=6	2
4		229-11606	FEED REGULATOR	1
5		229-11705	FEED REGULATOR BUSHING	1
6		SS-7120770-SH	SCREW 3/16-28 L=7	1
7		229-11804	FEED REGULATOR SCREW	1
8		229-12109	SPRING	1
9		229-12000	PIN	1
10		229-40506	FEED DIAL	1
11		SS-6121860-SP	SCREW 3/16-28 L=18	1
12		229-10202	ROCKER SHAFT CONNECTING ROD	1
13		229-11101	WALKING FOOT PIN C	1
14		SS-6090620-SP	SCREW 9/64-40 L=6	1
15		229-15003	CONNECTING ROD	1
16		RO-0922702-00	RUBBER RING	1
17		229-12406	FEED REVERSE SPRING	1
18		RE-0500000-K0	E-RING	1
19		229-12257	FEED REVERSE ARM ASM.	1
20		110-10410	FEED REVERSE ARM SCREW	1
21		RE-0500000-K0	E-RING	1
22		110-37405	ADJUSTING LINK SPRING B	1
23	#02	229-11408	FEED REGULATOR CONNCTING ROD	1
24		229-10905	WALKING FOOT PIN A	2
25		110-08703	WALKING FOOT LINK	2
26		110-08604	CONNECTING LINK A	2
27	#01	229-40951	FEED ADJUST LINK ASM.	1
28		229-10806	ADJUSTING LINK FULCRUM SHAFT A	2
29		SS-8150710-SP	SCREW 15/64-28 L=7	2
30		SS-6090620-SP	SCREW 9/64-40 L=6	2
31		229-40803	FEED BAR SHAFT	1
32		RC-0150001-KP	RETAINING RING 13.8	1
33		B1613-012-I00	FEED DOG I	1
34		SS-4080620-TP	SCREW 1/8-44 L=6	2
35		229-40753	FEED BAR ASM.	1
36		229-41306	ADJUSTING LINK SPRING GUIDE	1
37		SS-4110515-SP	SCREW 11/64-40 L=5	2
38		229-13701	FEED SPRING HOOK	1
39		229-12901	FEED ROCKER SHAFT	1
40		229-11002	WALKING FOOT PIN B	1
41		SS-6090620-SP	SCREW 9/64-40 L=6	1
42		NS-6680410-SP	NUT 9/32-28	1
43		229-10350	FEED ROCKER SHAFT CRANK ASM.	1
44		SS-6121610-SP	SCREW 3/16-28 L=15.5	(1)
45		229-15151	FEED ARM COMPL.	1
46		SS-7121610-SP	SCREW 3/16-28 L=15.5	(1)
47		SD-1000801-SH	HINGE SCREW D=10 H=8	1
48		229-15201	FEED DRIVING SHAFT	1
49		229-04155	THRUST COLLAR ASM.	1
50		SS-8660610-TP	SCREW 1/4-40 L=6	(2)
51		229-13008	FEED ROCKER SHAFT BUSHING	2
52	#03	229-13800	HORIZONTAL FEED ROD B	1
53		SS-7110740-TP	SCREW 11/64-40 L=7	1
54		RC-0150001-KP	RETAINING RING 13.8	1
55		229-40654	FEED BAR CRANK ASM.	1
56		SS-7121410-TP	SCREW 3/16-28 L=14	(1)
57		229-42056	DRIVING SHAFT CRANK ASM.	1
58		SS-7111120-SP	SCREW 11/64-40 L=10.5	(1)
59	#04	B1636-581-C00	NEEDLE BEARING	1
60	#02	229-10459	WALKING FOOT ADJUSTING LINK	1
61		229-04155	THRUST COLLAR ASM.	1
62		SS-8660610-TP	SCREW 1/4-40 L=6	(2)
63		RO-0781901-00	RUBBER RING	1
64		229-12604	FEED REVERSE SHAFT	1
65		229-12802	FEED LEVER METAL	1
66		SM-8061010-TP	SCREW	1
67		SM-8061050-TP	SCREW	1
68		229-12703	REVERSE FEED CONTROL LEVER	1
69		WP-0480856-SP	WASHER 4.8X8.4X0.8	1

Note #01...FOR DDL-8500-7-0B,-WB
 #02...FOR DDL-8500-7-00
 #03...FOR JE,JA
 #04...SELECTIVE PART(FOR JE,JA)

6. THREAD TRIMMER COMPONENTS

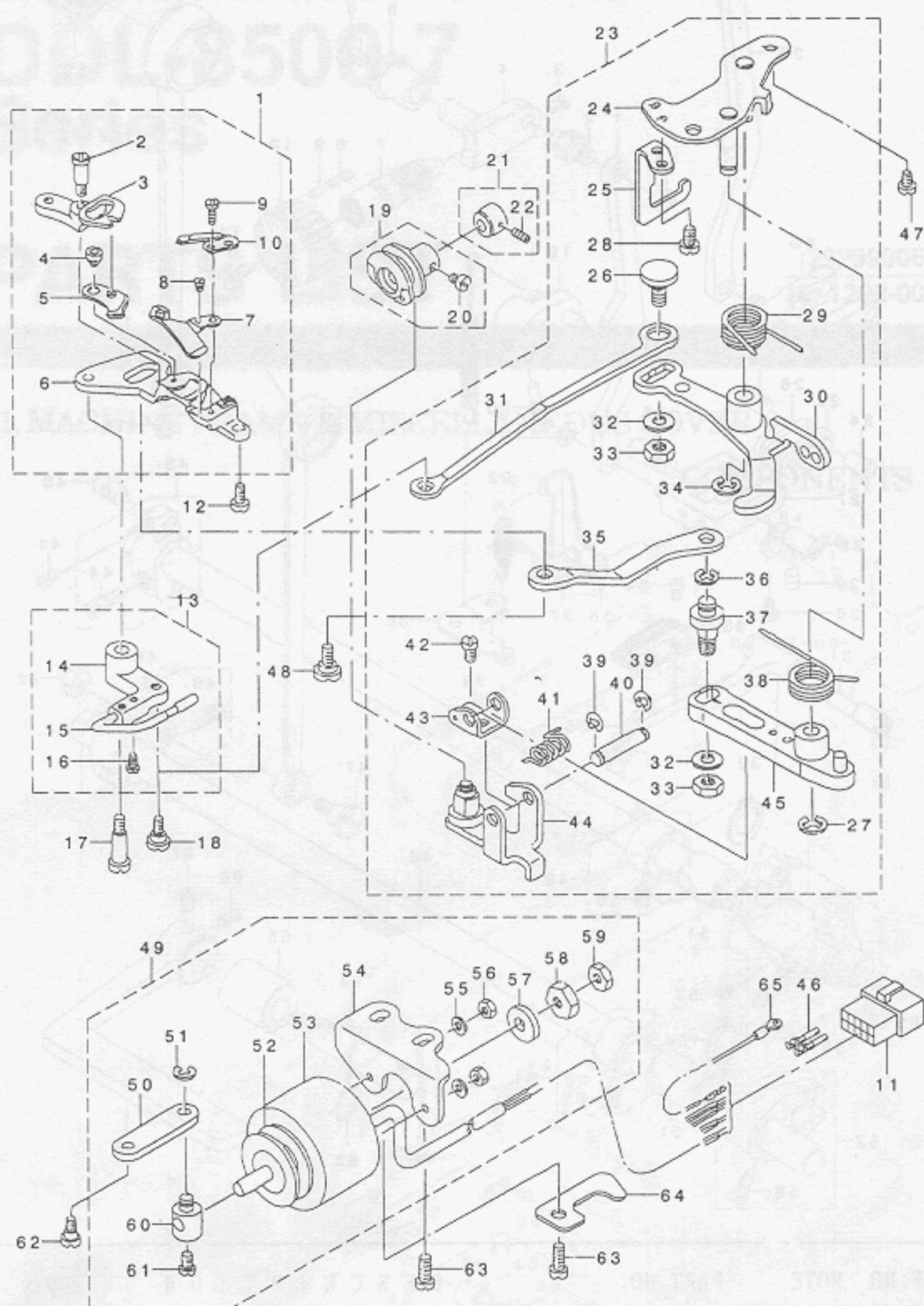

From the library of: Diamond Needle Corp

REF.NO	NOTE	PART NO.	DESCRIPTION	Qty
1		110-40359	KNIFE UNIT	1
2		SD-0460703-TP	HINGE SCREW D=4.6 H=7	(1)
3		110-40508	FORKED BASE FOR KNIFE	(1)
4		110-40409	MOVING KNIFE HINGE SCREW	(1)
5		110-40052	MOVING KNIFE ASM.	(1)
6		110-40300	KNIFE MOUNTING BASE	(1)
7		110-40201	THREAD GUIDE FOR KNIFE	(1)
8		SS-2060210-SP	SCREW 3/32-56 L=2.3	(1)
9		SS-4080620-TP	SCREW 1/8-44 L=6	(2)
10		D2406-555-DOH	COUNTER KNIFE	(1)
11		HK-0346101-40	HOUSING 14P	1
12		SS-4110715-SP	SCREW 11/64-40 L=7	1
13		229-50257	PICKER ARM ASM.	1
14		229-50208	PICKER ARM	(1)
15		229-50356	THREAD TAKE-UP PICKER ASM.	(1)
16		SS-6090510-SP	SCREW 9/64-40 L=5	(2)
17		SD-0641451-SP	HINGE SCREW D= 6.35 H=14.5	1
18		SD-0630275-SP	HINGE SCREW D= 6.35 H= 2.7	1
19		110-42850	THREAD TRIMMER CAM ASM.	1
20		SS-6660610-TP	SCREW 1/4-40 L=6	(2)
21		229-50950	CAM COLLAR ASM.	1
22		SS-8110520-TP	SCREW 11/64-40 L= 4.5	(1)
23		229-49762	THREAD TRIMMER DRIVING UNIT	1
24		229-49754	BASE PLATE ASM.	(1)
25		229-50703	DRIVING ARM STOPPE	(1)
26		229-50000	PICKER LINK PIN	(1)
27		RE-0600000-KO	E-RING 6	(1)
28		SS-4110715-SP	SCREW 11/64-40 L=7	(2)
29		229-49408	CLUTCH SPRING	(1)
30		110-41852	CLUTCH PLATE ASM.	(1)
31		229-50109	PICKER LINK	(1)
32		WP-0621016-SH	WASHER	(2)
33		NS-6150430-SP	NUT 15/64-28	(2)
34		RE-0600000-KO	E-RING 6	(1)
35		110-40607	MOVING KNIFE LINK	(1)
36		RE-0500000-KO	E-RING	(1)
37		229-48400	MOVING KNIFE LINK PIN	(1)
38		229-49309	KNIFE RETURN SPRING B	(1)
39		RE-0400000-KO	E-RING 4	(2)
40		229-49101	ROLLER FULCRUM SHAFT	(1)
41		229-49200	ROLLER FULCRUM SPRING	(1)
42		SS-7090610-SP	SCREW 9/64-40 L=6	(1)
43		229-49002	ROLLER ARM BRACKET	(1)
44		229-48657	ROLLER ARM ASM.	(1)
45		110-40854	KNIFE DRIVING ARM ASM.	(1)
46		HK-0346400-0B	PIN CONTACT	2
47		SS-4150915-SP	SCREW 15/64-28 L=9	2
48		SD-0640631-TP	HINGE SCREW D=6.35 H=6.3	1
49		229-51164	SOLENOID UNIT	1
50		229-49903	CLUTCH LINK	(1)
51		RE-0500000-KO	E-RING	(1)
52		110-43205	SOLENOID RUBBER A	(1)
53		110-43908	THREAD TRIMMER SOLENOID	(1)
54		229-51404	SOLENOID BASE	(1)
55		WP-0450000-SD	WASHER 4.5X8X0.5	(2)
56		NM-6040000-SN	NUT M4	(2)
57		110-43304	SOLENOID RUBBER	(1)
58		NS-6660410-SH	NUT	(1)
59		NS-6660430-SP	NUT 1/4-40	(1)
60		229-51008	SOLENOID PIN	(1)
61		SS-6110710-TP	SCREW 11/64-40 L= 6.5	(1)
62		SD-0600361-SP	HINGE SCREW D=6 H=3.6	1
63		SS-4151215-SP	SCREW 15/64-28 L=12	2
64		229-24807	TUBE HOLDER ,LOWER	1
65		110-44054	GROUND WIRE ASM.	1

7. AUTOMATIC REVERSE FEED COMPONENTS

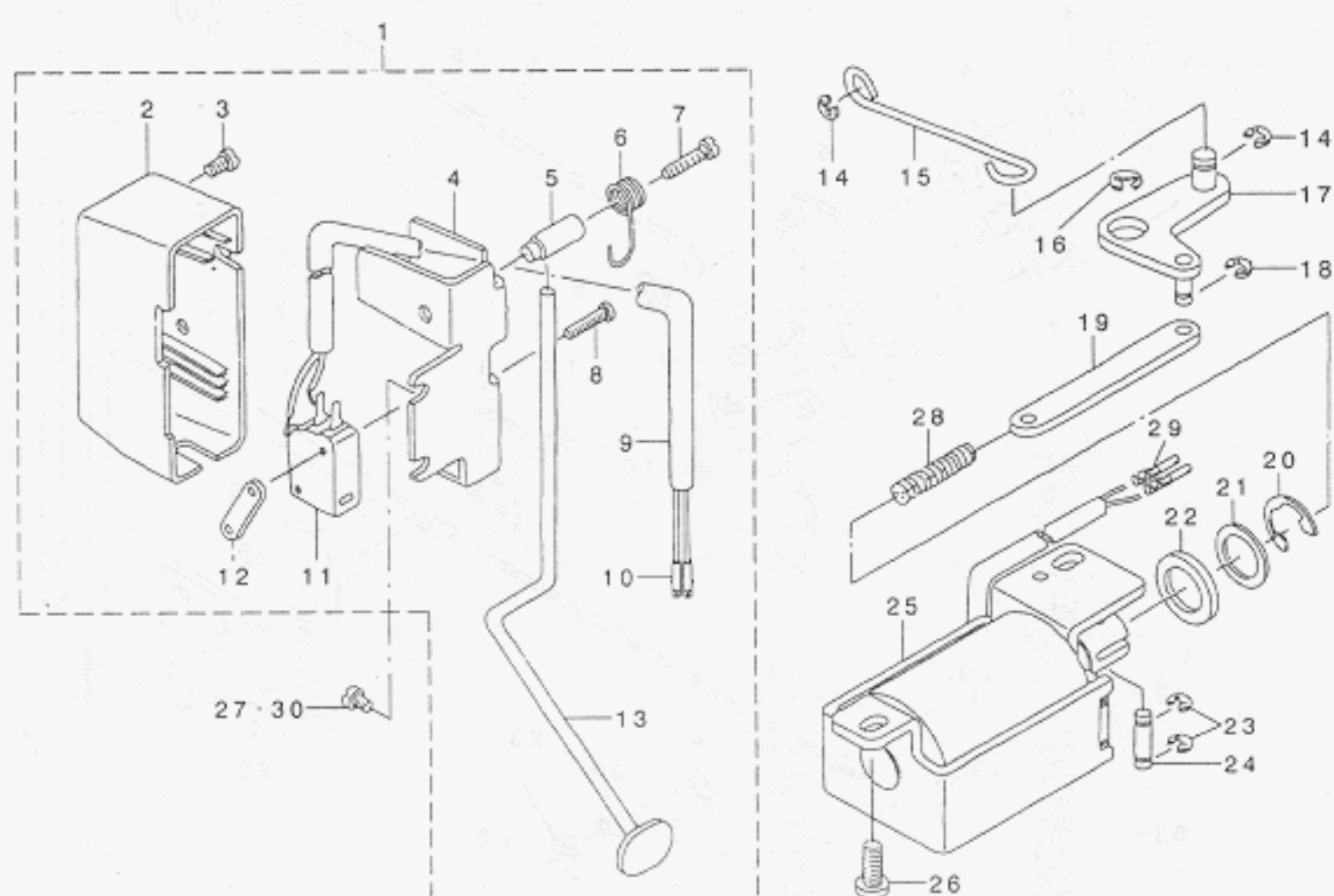

REF.NO	NOTE	PART NO.	DESCRIPTION	Qty
1		229-54150	REVERSE FEED SWITCH ASM.	1
2		229-54606	REVERSE FEED SWITCH COVER	(1)
3		SM-4040655-SP	SCREW M4 L=6	(1)
4		229-54101	REVERSE FEED SWITCH BASE	(1)
5		229-54200	REVERSE FEED SWITCH SHAFT	(1)
6		229-54309	REVERSE FEED SWITCH SPRING	(1)
7		SM-4041655-SP	SCREW M4 L=16	(1)
8		SM-4031501-SC	SCREW M3 L=15	(2)
9		HW-5000700-00	2-CORE CABTYRE CORD	(1.31)
10		HK-0346400-0B	PIN CONTACT	(2)
11		HA-0019000-00	MICROSWITCH	(1)
12		229-54408	SWITCH HOLDING PLATE	(1)
13		229-54507	REVERSE FEED SWITCH LEVER	(1)
14		RE-0500000-KP	E-RING 5	2
15		229-53806	REVERSE FEED CONNECTING SHAFT	1
16		RE-0900000-K0	E-RING 9	1
17		229-53657	CONNECTING ARM ASM.	1
18		RE-0400000-KP	E-RING 4	1
19		229-53905	REVERSE FEED CONNECTING LINK	1
20		RE-1200000-K0	E-RING 12	1
21		WP-1602616-SZ	WASHER 16X24X2.6	1
22		D2468-555-B00	RUBBER PLUNGER	1
23		RE-0400000-K0	E-RING 4	2
24		229-53509	PLUNGER ARM PIN	1
25		111-02753	REVERSE FEED MAGNET ASM.	1
26		SS-4151215-SP	SCREW 15/64-28 L=12	2
27		SS-4120915-SP	SCREW 3/16-28 L=9	1
28		229-54002	PLUNGER SPRING	1
29		HK-0346400-0B	PIN CONTACT	2
30	#01	SS-4120615-SP	SCREW 3/16-28 L=6	1

Note #01....FOR DDL-8500-7-0B

9. OIL LUBRICATION COMPONENTS

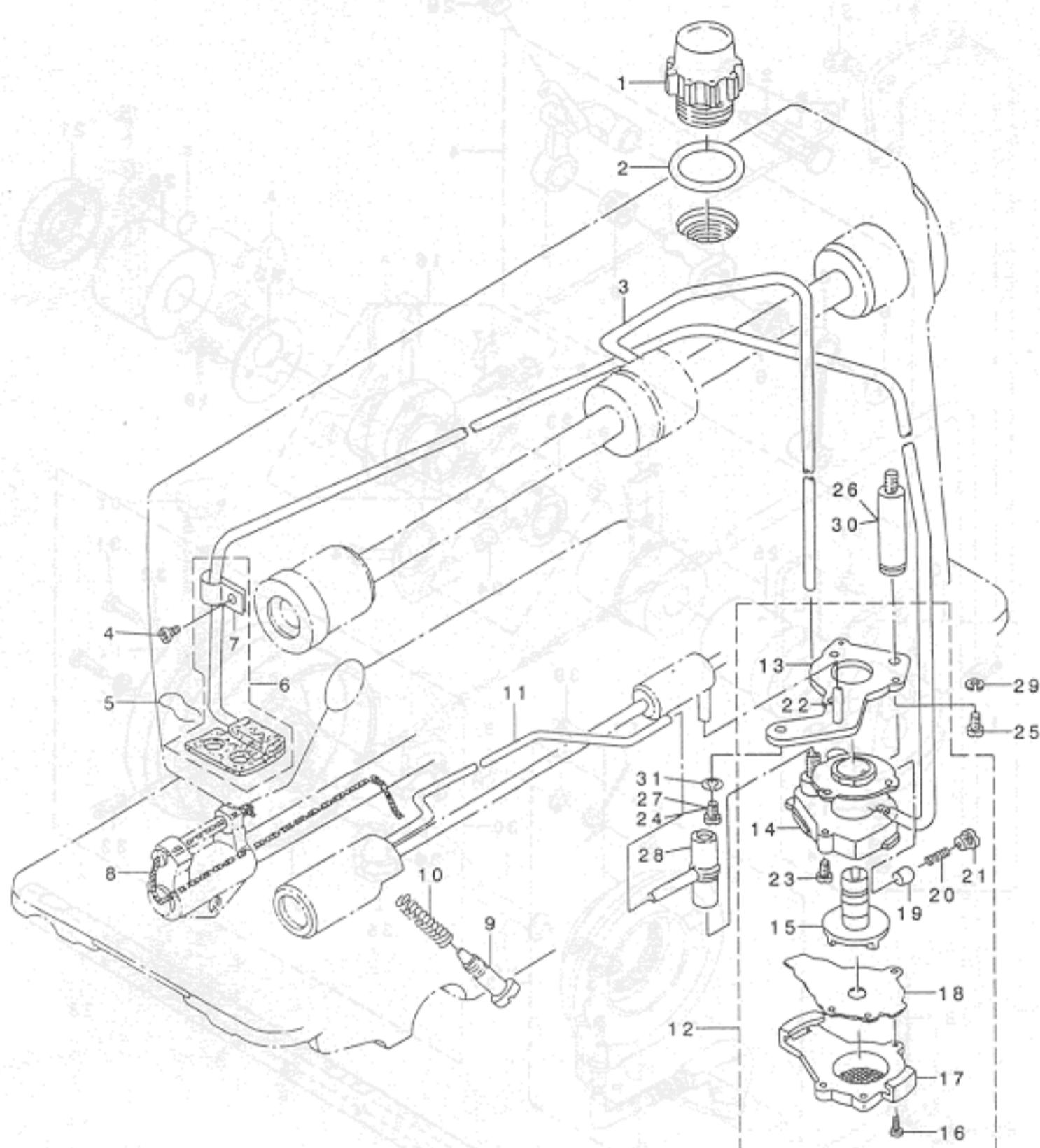

From the library of: Diamond Needle Corp

REF.NO	NOTE	PART NO.	DESCRIPTION	Qty
1		229-47006	OIL SIGHT WINDOW	1
2		RO-1952401-00	RUBBER RING	1
3		229-24401	MAIN SHAFT OIL TUBE	1
4		SS-4120615-SP	SCREW 3/16-28 L=6	1
5		229-25101	OIL FELT PRESSER	1
6		229-24153	OIL RETURN TUBE ASM.	1
7		229-24302	HOLDER	(1)
8		CQ-2520000-00	OIL WICK	0.21
9		229-25002	OIL ADJUSTING SCREW	1
10		229-24906	SPRING	1
11		229-24500	OIL TUBE	1
12		229-23056	LUBRICATING OIL PUMP ASM.	1
13		229-23304	OIL PUMP INSTALLING BASE	(1)
14		229-23007	OIL PUMP	(1)
15		229-23700	OIL PUMP IMPELLER	(1)
16		SE-4301041-SR	SCREW D=3 L=10	(3)
17		229-23205	LUBRICATING OIL PUMP COVER	(1)
18		229-23809	OIL PUMP IMPELLER COVER	(1)
19		229-23403	PLUNGER	(1)
20		229-23601	PLUNGER SPRING	(1)
21		229-23502	PLUNGER SCREW	(1)
22		229-23908	HOOK DRIVING SHAFT OIL TUBE	(1)
23		SL-4030851-SF	SCREW M3 L=8	(3)
24	#02	SS-4150915-SP	SCREW 15/64-28 L=9	1
25		SS-6111010-TP	SCREW 11/64-40 L= 9.5	1
26	#01	229-47105	OIL PUMP SUPPORT	1
27	#01	SS-4151215-SP	SCREW 15/64-28 L=12	1
28		229-24609	RUBBER JOINT	1
29	#01	WS-0451040-KP	SPRING WASHER 4.5X8.5X1	1
30	#02	229-24005	OIL PUMP SUPPORT	1
31	#01	WS-0651310-KP	SPRING WASHER 6.5X11X1.3	1

Note #01...FOR DDL-8500-7-0B,-WB
 #02...FOR DDL-8500-7-00

10. OIL RESERVOIR COMPONENTS

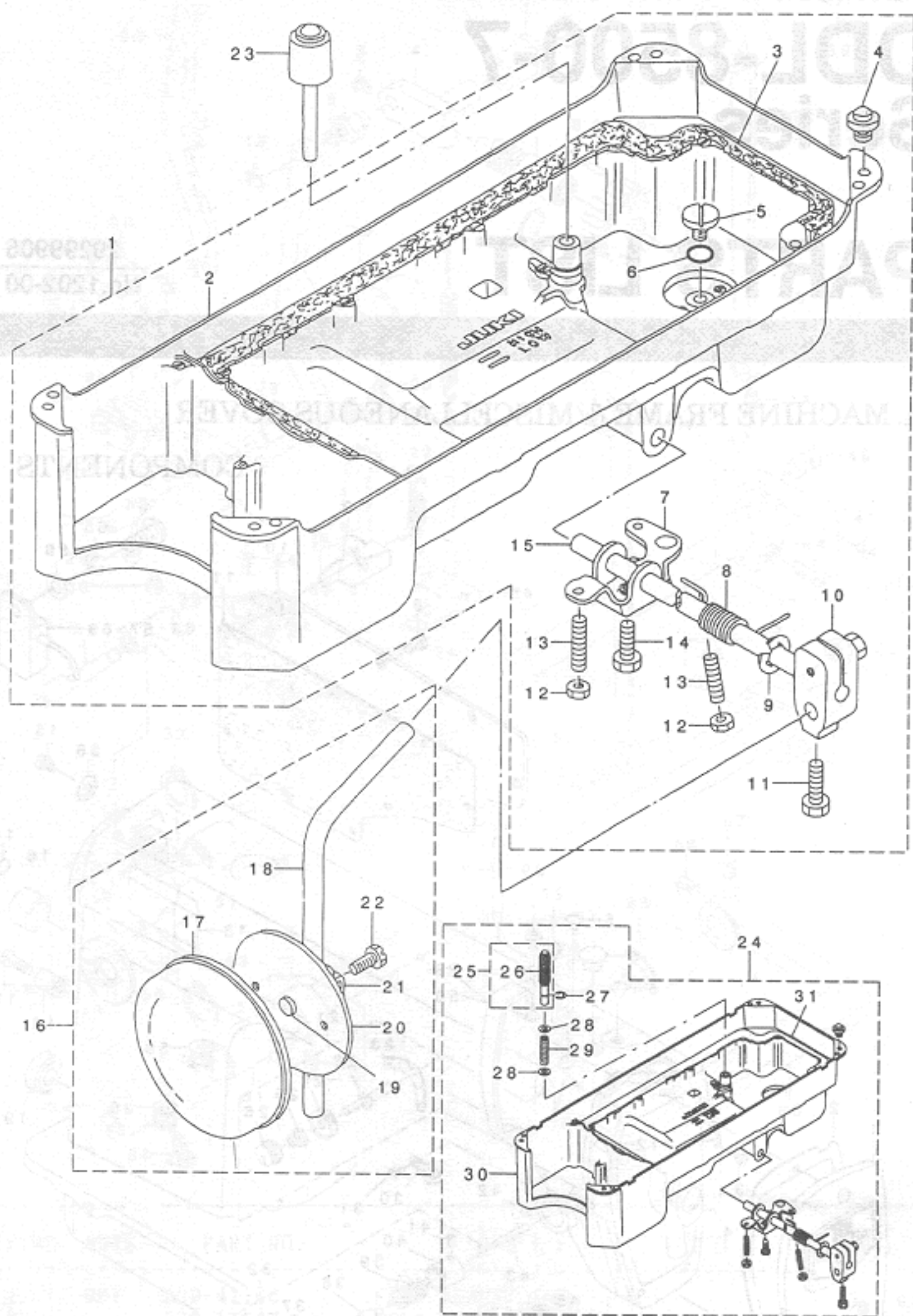

REF.NO	NOTE	PART NO.	DESCRIPTION	Qty
1		110-47057	OIL RESERVOIR ASM.	1
2		110-23017	OIL RESERVOIR	(1)
3		110-24700	GASKET	(1)
4		110-47107	RUBBER CUSHION	(4)
5		SS-6700710-SH	SCREW 5/16-24 L=7	(1)
6		RO-1082401-00	RUBBER RING	(1)
7		110-24015	CONNECTING ROT, VERTICAL	(1)
8		110-24106	SPRING	(1)
9		RE-1000000-K0	E-RING 10	(1)
10		110-24510	BRACKET	(1)
11		SM-9062053-SR	SCREW M6 L=20	(2)
12		NM-6060001-SE	NUT M6	(2)
13		SM-8063012-TR	SCREW M6 L=30	(2)
14		SM-9061853-SR	SCREW M6 L=17.5	(1)
15		110-24205	KNEE PRESS ROD	(1)
16		229-34251	KNEE PRESS PLATE ASM.	1
17		229-34509	KNEE PRESS PLATE COVER	(1)
18		229-34608	KNEE PRESS PLATE ROD	(1)
19		229-34400	KNEE PRESS PLATE RUBBER	(1)
20		229-34202	KNEE PRESS PLATE	(1)
21		229-34301	KNEE PRESS PLATE HOLDER	(1)
22		SM-9061203-SE	SCREW M6 L=12	(1)
23		229-31703	KNEE PRESS LIFTER ROD	1
24	#01	111-41454	OIL RESERVOIR ASM.	1
25	#01	GAK-300010B0	KNEE PRESS LIFTER ROD ASM.	(1)
26	#01	GAK-30004000	KNEE PRESS LIFTER ROD RUBBER	(1)
27	#01	RE-0400000-K0	E-RING 4	(1)
28	#01	WP-0621016-SD	WASHER 6.2X13X1	(2)
29	#01	GAK-30005000	SPRING	(1)
30	#01	111-41413	OIL RESERVOIR	(1)
31	#01	111-41900	GASKET	(1)

Note #01....FOR JE & JO

11. BELT COVER & BOBBIN COMPONENTS

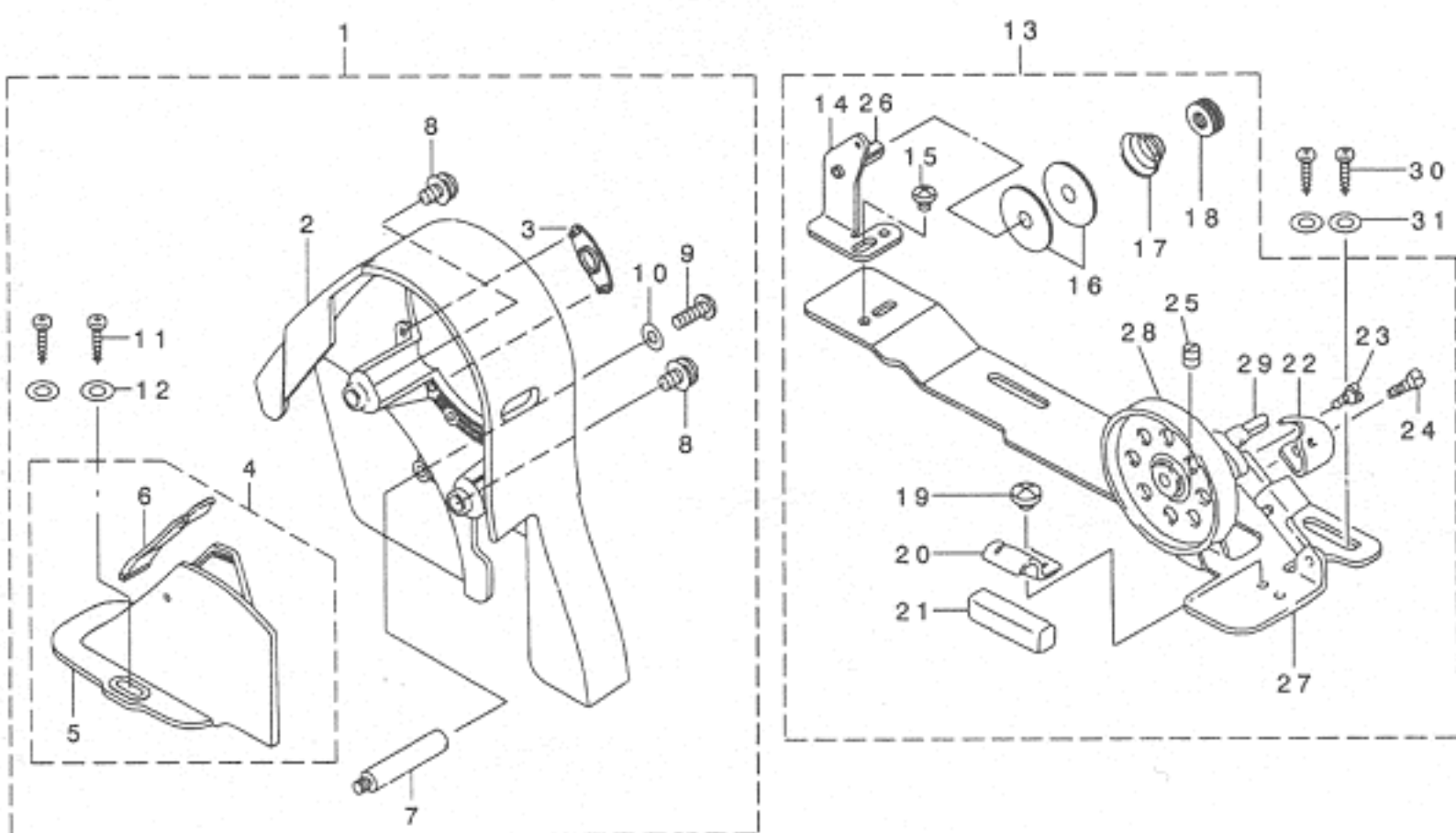

REF.NO	NOTE	PART NO.	DESCRIPTION	Qty
1		229-33451	BELT COVER ASM.	1
2		229-33402	BELT COVER A	(1)
3		229-33501	BELT COVER A CAP	(1)
4		229-33659	BELT COVER B ASM.	(1)
5		229-33600	BELT COVER B	(1)
6		229-33758	BELT COVER B CAP ASM.	(1)
7		229-33907	BELT COVER SUPPORT ,A	(1)
8		229-34004	BELT COVER A SCREW	(2)
9		SS-4121415-SP	SCREW 3/16-28 L=14	(1)
10		WP-0501016-SD	WASHER 5X10.5X1	(1)
11		SK-3412000-SC	WOOD SCREW D=4.1 L=20	(2)
12		WP-0450826-SC	WASHER 4.5X10X0.8	(2)
13		229-27354	BOBBIN WINDER COMPL.	1
14		229-28501	THREAD TENSION BRACKET	(1)
15		SS-4110515-SP	SCREW 11/64-40 L=5	(1)
16		229-28907	THREAD TENSION DISK	(2)
17		229-29004	THREAD TENSION SPRING	(1)
18		229-28808	THREAD TENSION NUT	(1)
19		SS-7110350-SP	SCREW 11/64-40 L=3.5	(1)
20		229-28402	RUBBER BRAKE PRESSER PLATE	(1)
21		229-28303	RUBBER BRAKE	(1)
22		229-28105	POSITIONING FINGER	(1)
23		SD-0490261-SP	HINGE SCREW D=4.9 H=2.6	(1)
24		SS-7081310-SP	SCREW 1/8-44 L=12.5	(1)
25		SS-8110510-SP	SCREW 11/64-40 L=5	(1)
26		229-28709	THREAD TENSION BRACKET	(1)
27		229-27305	BOBBIN BASE	(1)
28		229-27404	BOBBIN PULLEY	(1)
29		229-27602	BOBBIN WINDER POST	(1)
30		SK-3412000-SC	WOOD SCREW D=4.1 L=20	2
31		WP-0450826-SC	WASHER 4.5X10X0.8	2

12. THREAD STAND COMPONENTS

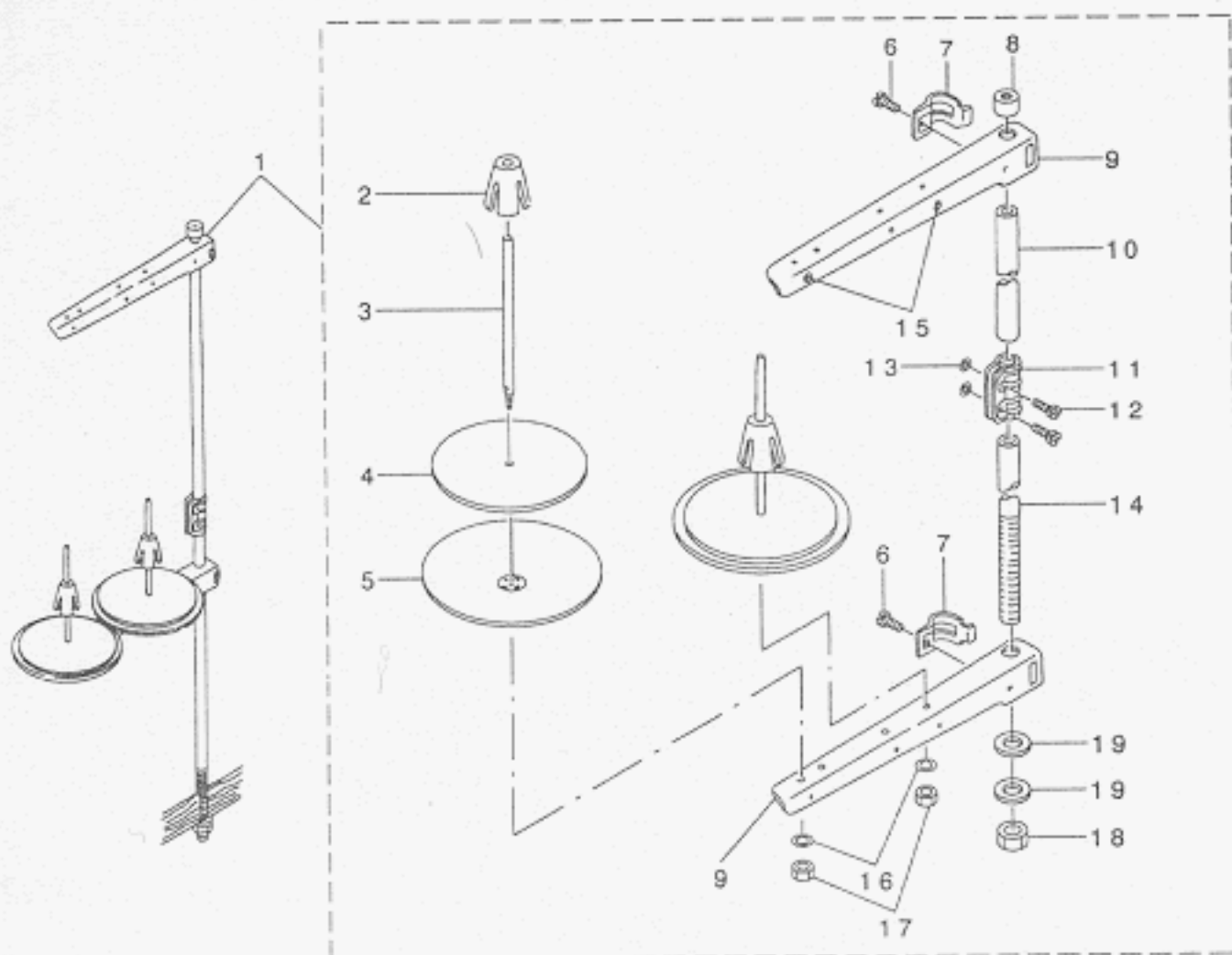

REF.NO	NOTE	PART NO.	DESCRIPTION	Qty
1		229-30358	THREAD STAND ASM.	1
2		229-31109	SPOOL RETAINER	(2)
3		229-31000	SPOOL PIN	(2)
4		229-30903	SPOOL REST CUSHION	(2)
5		229-30804	SPOOL REST	(2)
6		SM-6061610-SC	SCREW M6 L=16	(2)
7		229-30705	THREAD GUIDE ARM JOINT	(2)
8		229-31406	SPOOL REST ROD RUBBER CAP	(1)
9		229-30507	SPOOL REST ARM	(2)
10		229-30408	SPOOL REST ROD, UPPER	(1)
11		229-31307	SPOOL REST ROD JOINT	(1)
12		SM-4051405-SE	SCREW M5 L=14	(2)
13		NM-6050001-SE	NUT M5	(2)
14		229-30309	SPOOL REST ROD, LOWER	(1)
15		229-31208	THREAD GUIDE	(2)
16		WS-0510002-KN	SPRING WASHER	(2)
17		NM-6050001-SE	NUT M5	(2)
18		NM-6160511-SE	NUT M16X1.5	(1)
19		WP-1702600-S0	WASHER 17X30X2.6	(2)

13. EXCLUSIVE PARTS FOR DDL-8500H-7

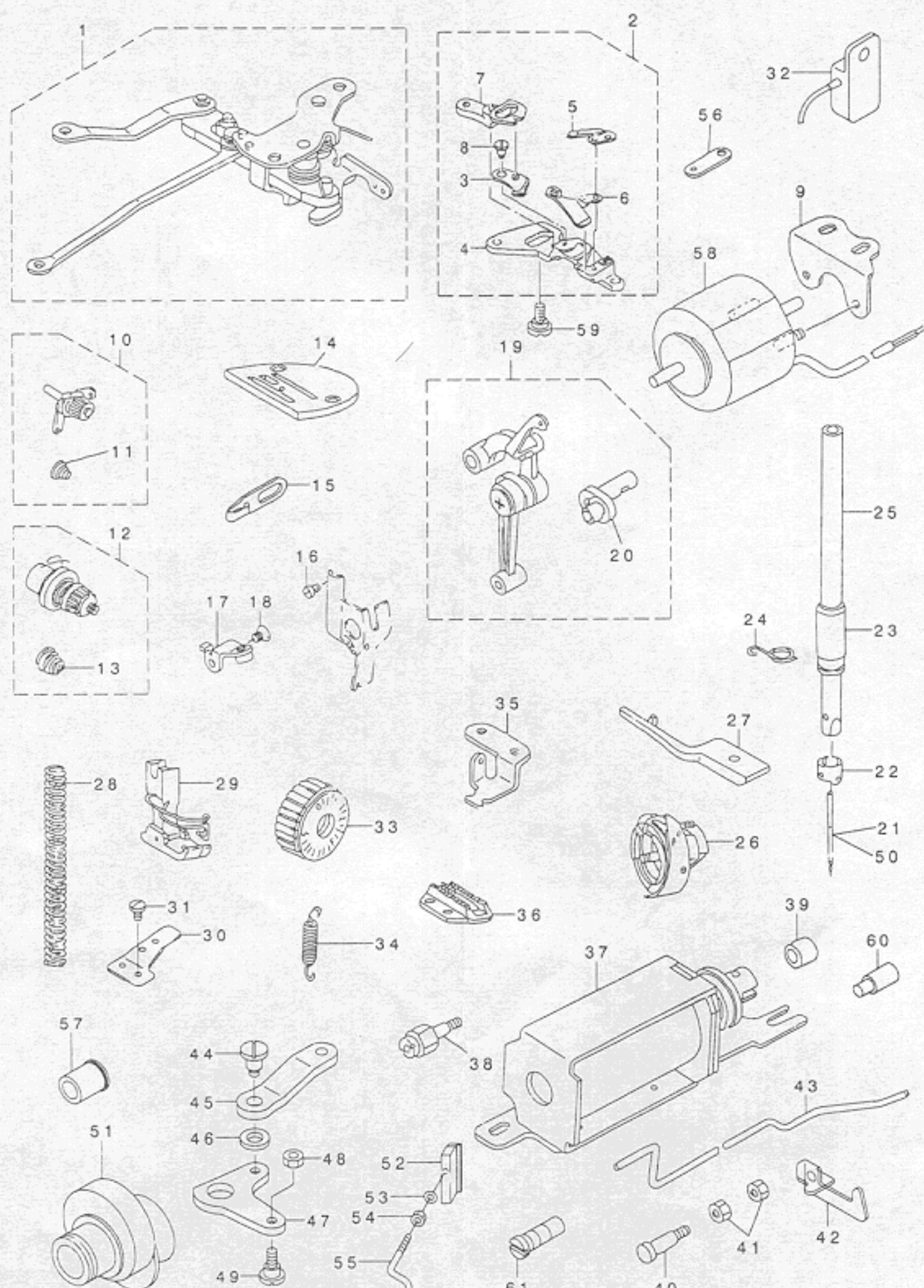

REF. NO	NOTE	PART NO.	DESCRIPTION	Qty
1		110-96062	THREAD CUTTING DRIVING UNIT	1
2		110-95551	KNIFE UNIT	1
3		114-09257	MOVING KNIFE J ASM.	(1)
4		110-95502	KNIFE MOUNT BASE	(1)
5		114-09604	FIX KNIFE	(1)
6		110-95403	KNIFE THREAD GUIDE	(1)
7		110-95601	KNIFE BRANCH	(1)
8		SD-0500131-TP	HINGE SCREW D=5 H=1.25	(1)
9		110-94901	SOLENOID BASE	1
10		110-73954	THREAD TENSION ASM.	1
11		110-93606	THREAD TENSION SPRING	(1)
12		110-73657	THREAD TENSION ASM.	1
13		B3114-232-000	THREAD TENSION SPRING	(1)
14		114-00801	THROAT PLATE J	1
15		110-91006	ARM THREAD GUIDE (HA)	1
16		SS-6080320-SP	SCREW 1/8-44 L= 2.5	1
17	#02	110-95254	LEVER STOPPER ASM.	1
18	#02	SS-1120710-SP	SCREW 3/16-28 L=6.5	1
19		110-91659	LINK THREAD TAKE-UP LEVER ASM.	1
20		110-91600	NEEDLE BAR CRANK H	(1)
21		MDB-100B2100	NEEDLE DBX1 #21	1
22		B1418-415-H00	NEEDLE BAR THREAD GUIDE	1
23		B1403-553-000	NEEDLE BAR BUSHING, LOWER	1
24		B1419-553-000	NEEDLE BAR THREAD GUIDE	1
25		110-91303	NEEDLE BAR	1
26		110-92251	LUBRICATING BOBBIN ASM.	1
27		110-93804	POSITIONING FINGER H	1
28		B1505-552-000-A	PRESSER SPRING	1
29		D1524-555-EBL	PRESSER FOOT ASM.	1
30	#02	112-30901	WIRE PRESSER PLATE, B	1
31	#02	SS-7110740-TP	SCREW 11/64-40 L=7	1
32		M6009-350-AAA	RESISTANCE PACK AA ASM.	1
33		229-11903	FEED DIAL	1
34		110-91204	ADJUST LINK SPRING	1
35		110-91907	FEED SPRING HOOK	1
36		114-03003	FEED J	1
37	#02	110-96658	SOLENOID MOUNTING BASE ASM.	1
38	#02	112-31503	OIL PUMP SUPPORT	1
39	#02	112-28103	REVERSE FEED BASE COLLAR	1
40	#02	113-14408	PLUNGER ARM PIN	1
41	#02	NS-6110420-SP	NUT 11/64-40	2
42	#02	112-28301	TUBE HOLDER, LOWER	1
43		110-94109	OIL TUBE	1
44	#02	SD-0700711-TP	HINGE SCREW D=7 H=7.1	1
45	#02	111-01607	SOLENOID CONNECTING LINK	1
46	#02	WP-0722316-SH	WASHER	1
47	#02	111-01508	REVERSE FEED LINK	1
48	#02	NS-6110420-SP	NUT 11/64-40	1
49	#02	SD-0700451-TP	HINGE SCREW D=7 H=4.5	1
50	#01	MC-2005013-00	NEEDLE 134 NM130	1
51		110-80900	FEED DRIVE ECCENTRIC CAM	1
52		114-03805	THREAD GUIDE C FITTING PLATE	1
53		WP-0371016-SD	WASHER 3.7X8X1	1
54		NS-6090310-SP	NUT 9/64-40	1
55		113-05513	ARM THREAD GUIDE, C	1
56		110-94604	CLUTCH LINK	1
57	#02	110-09800	FEED REGULATOR BUSHING	1
58		110-96500	THREAD TRIMMER SOLENOID	1
59		SD-0550701-TP	STEP-SCREW D=5.5 H=7	1
60	#02	110-08901	ADJUSTING LINK FULCRUM SHAFT B	1
61		B1213-552-000-A	OIL ADJUSTING PIN	1

Note #01....FOR JE
#02....FOR DDL-8500H-7-0B, -WB

14. EXCLUSIVE PARTS FOR DDL-8500A-7

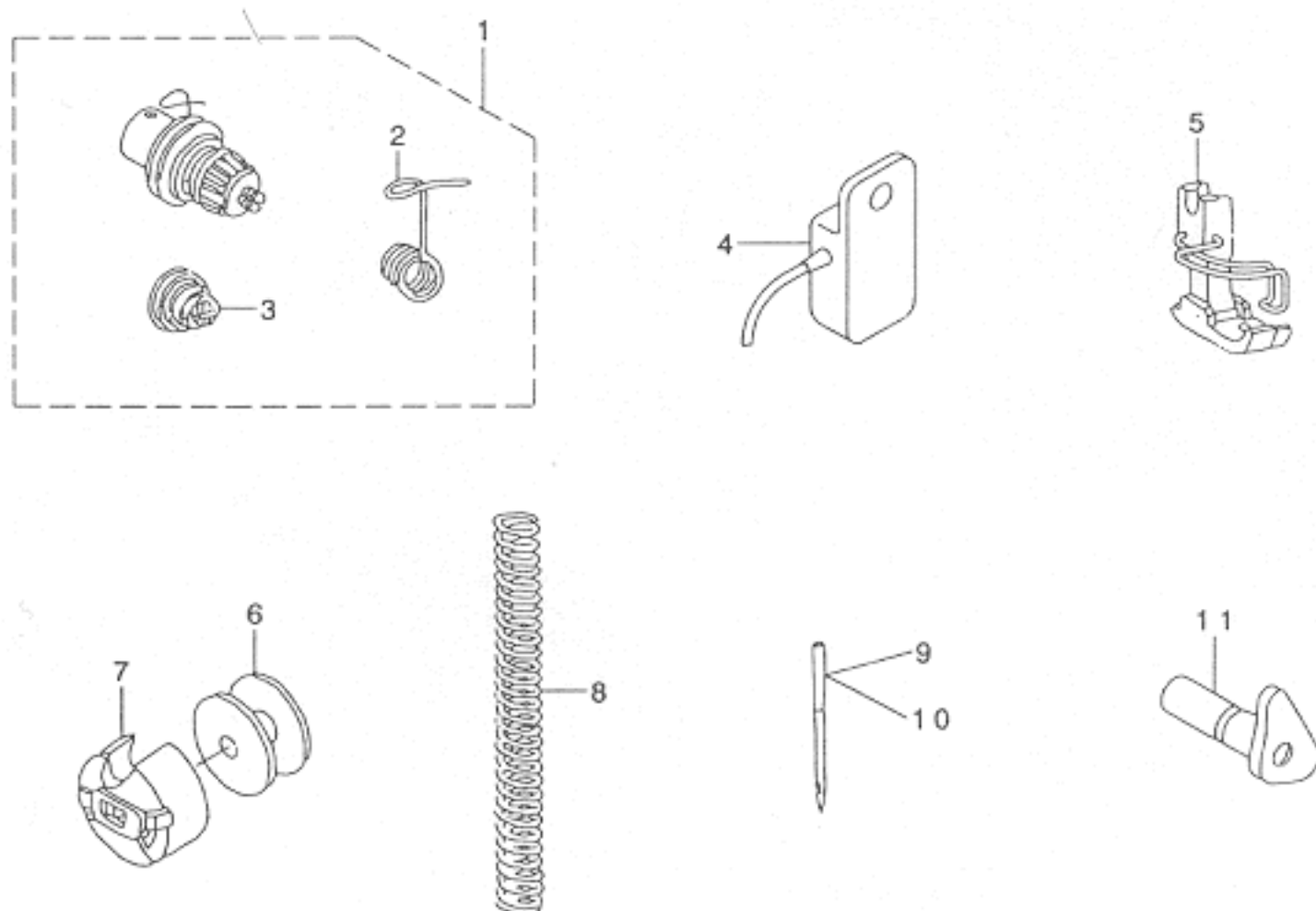

REF. NO	NOTE	PART NO.	DESCRIPTION	Qty
1		110-73756	THREAD TENSION ASM.	1
2		D3128-555-D00	TAKE-UP SPRING	(1)
3		D3129-555-D00	THREAD TENSION SPRING	(1)
4		M6018-350-AAA	RESISTANCE PACK AA ASM.	1
5		D1524-555-DBA	PRESSER FOOT ASM.	1
6		B9117-552-A00	BOBBIN	1
7		B1837-012-OA0	BOBBIN CASE ASM.	1
8		B1505-227-T00-A	PRESSER SPRING T	1
9	#01	MC-2005006-50	NEEDLE 134 NM65	1
10		MDA-100B0900	NEEDLE DAX1 #9	1
11		110-92558	HAND LIFTER CAM ASM.	1

Note #01....FOR JE